

ANALEXrs

Total Ferrous Debris Sensor



Remote Sensors - the online link between your machines and ultimate reliability

ANALEXrs

Total Ferrous Debris Sensor



Machine Wear Costs Money!

Without a doubt, you're running a high quality maintenance programme.

You feel confident you have it all under control.

That critical plant is in safe hands.

Operating schedules are going to be met.

Or are they?

What if the plant stops because of failure of that critical machine?

What about the repair costs, the downtime, the loss of revenue? Never mind the added risk to personnel health and safety, or the environment.

You probably already know that machines give telltale indicators of potential problems. Any change in the wear pattern is going to result in changes in the ferrous density. **That's why your oil analysis service includes a PQ result.**

But how frequently are you sampling? What if a problem arises between scheduled samples?

Wouldn't it make sense to be monitoring more frequently?

Well now you can. **The ANALEXrs Ferro range of online sensors puts your oil analysis laboratory on your doorstep.**



Brought to you by the same company that has been successfully delivering millions of PQ results to engineers the world over from hundreds of laboratories for the last 25 years. And now manufactured by Kittiwake, a company that has been delivering low-cost, robust field instrumentation to the lubricants and fuels market for over 15 years.

The ANALEXrs Total Ferro Debris Sensor goes beyond the normal chip detectors and magnetic plugs. Providing a ppm value, now you can monitor real-time. And take immediate action on the first indication of change. **It goes beyond the normal protection systems; it prevents failure, not just catastrophic failure.**

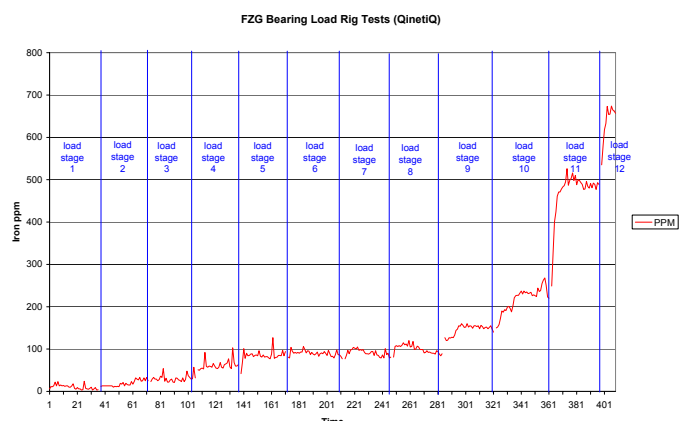

ANALEXrs

Technical Specifications

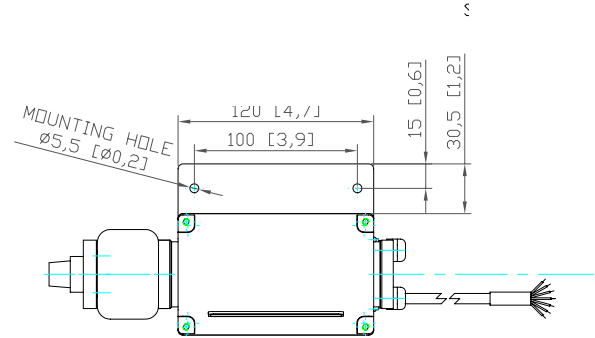
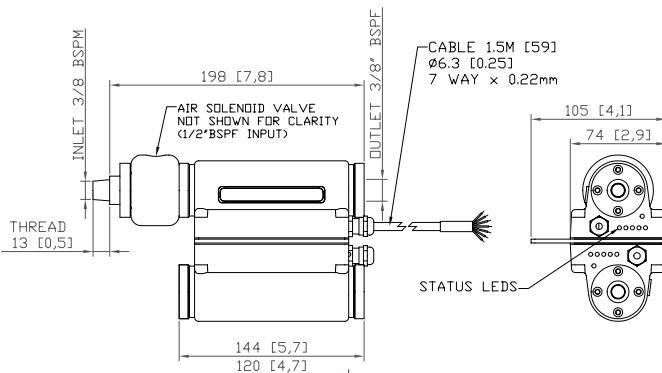

Detection	Total Ferrous Wear Debris
Analogue Outputs	Opto isolated 4-20mA
Communications	CAN, RS232, RS485, (802.11b WLAN optional)
Connections	Oil 3/8" (Inlet BSPT male, outlet BSPP female), Air 1/2" BSPP female
Range	0-2000 ppm
Power Supply	18-36 VDC
Protection	IP65
Max Fluid Pressure	10 Bar (145 psi)
Fluid Compatibility	Petroleum, synthetic oils and water/oil emulsions
Fluid Temperature	-20 to 80°C (-4 to 176°F)
Ambient Temperature	-20 to 65°C (-4 to 149°F)
Weight	2.2kg (4.85lb)
Features	Automatic operation Robust construction
Options	Stand alone unit Unit with automatic air blast zeroing Unit with automatic piston zeroing Display/Alarm box 802.11b WLAN interface

The ANALEXrs Total Ferro Debris Sensor can be mounted within any lubrication system on any type of machine. The sensor measures ferrous density, resulting from the wear debris within the lubricant, using a combination of proven magnetometry, combined with smart algorithms to provide data in Parts Per Million (ppm).

With its digital and analogue outputs, it can be easily integrated into your existing Condition Monitoring and operating control systems. **ANALEXrs puts you in control.** Whether it's to check on the health of the machine, or an alert of changing wear patterns, the ANALEXrs Total Ferro Debris Sensor provides instant information, complementing your existing laboratory oil analysis programme, and helping you make informed maintenance planning decisions.

- Robust cast Iron enclosure providing strength and magnetic shielding
- Air Blast or Piston versions available for use in multitude of applications
- 3/8" BSP connections for quick and easy installation
- Sealed to IP65 suitable for industrial use
- Reference coil for controlled temperature stability
- LED display providing a visual indication of sensor status
- Wide range of interface options due to variety of industry standard outputs

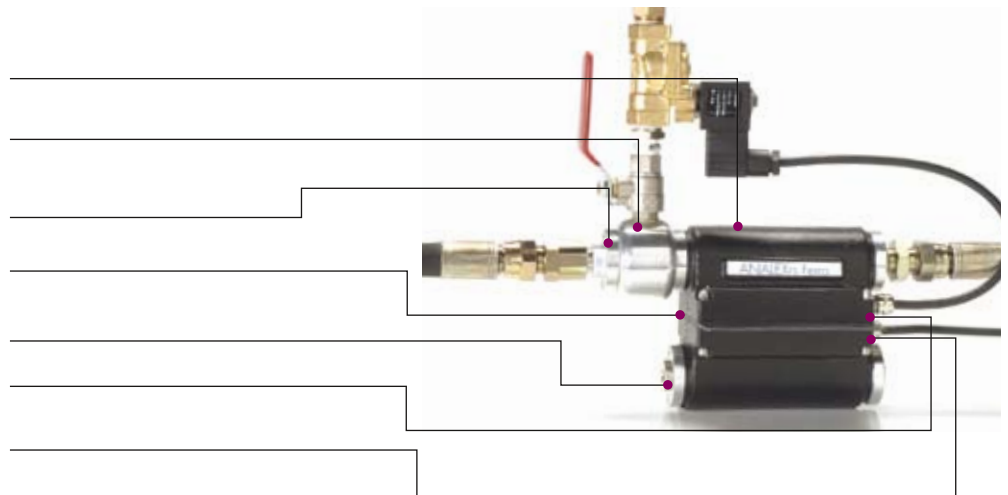

ANALEXrs

Technical Specifications and Applications

Typical applications:

The sensor will prove most valuable when used with machines that are either:

- A high capital cost
- Production critical
- Safety critical
- Costly to repair
- Have long lead times on spares.
- Remote locations



ANALEXrs equipment can be fitted on any machine with a lubrication system, and where ferrous debris is a predominant measure of the wear rate.

Examples include equipment such as:

- Engines
- Gearboxes & Transmissions
- Bearings
- Pumps
- Compressors
- Turbines

Industries such as:

- Power Generation (Steam, Nuclear, Wind turbine)
- Steel
- Pulp & Paper
- Petro-chemical/refineries
- Transportation
- Military

Specifications	Total Ferrous Debris Sensor	Oil Condition Sensor	Particle Content Sensor	Moisture Sensor
Product Code	FG-K16120-KW	FG-K14492-KW/FG-K16203-KW	FG-K16121-KW	FG-K16291-KW
Detection	Total Ferrous Wear Debris 0-2000ppm	Oil Condition 0-100 Oil Quality Units	Ferrous Particles > 100µm and Metallic Non-Ferrous Debris Particles > 200µm	0-100% Saturation
Analogue Output	4-20mA	4-20mA	4-20mA	4-20mA % saturation, Temperature of Oil, RH Alarm
Digital Output	CAN, RS232, RS485, radio link	RS232, CAN	CAN, RS232, RS485, radio link	CAN, RS232 at 9600baud
Power	18-36 VDC	15-30 VDC, 1 watt max	18-36 VDC	12-30Vdc <1w
Maximum Fluid Pressure	10 bar (145psi)	10 bar (145psi)	10bar (145psi)	10bar (145psi)
Fluid Temperature	-20 to 65°C (-4 to 149°F)**	30 to 100°C (86 to 212°F)	-20 to 65°C (-4 to 149°F)**	-40 to 100°C (-40 to 212°F)
Protection	IP65	IP67	IP65	IP67
Sensor Weight	2.2kg (4.85lb)	250g (9oz)	1.4 kg (3.1lb)	300g (10.6oz)

**Kittiwake operates a continuous development program and thus certain specifications may be subject to change.
nb: Visit the Kittiwake website to view the latest case study data, detailed specifications and technical information.

Kittiwake Developments Ltd

3 - 6 Thorgate Road, Littlehampton, West Sussex, BN17 7LU, UK.
Tel: + 44 (0) 1903 731470 Fax: + 44 (0) 1903 731480
Email: sales@kittiwake.com Web: www.kittiwake.com

Kittiwake GmbH

Bertha von Suttner Str. 10, 25337 Elmshorn, Germany
Tel: + 49 (4121) 463948 Fax: + 49 (4121) 463949
Email: m.winkler@kittiwake.de Web: www.kittiwake.de

Kittiwake Asia Pacific

NO 9 & 11, Level 1-6, Block C-1, Jalan PJU 1/41, Dataran Prima, 47301 Petaling Jaya, Selangor D.E., Malaysia
Tel: + 60 (0) 3 2093 7637
Email: martinl@kittiwake.com



INVESTOR IN PEOPLE

